

Communication Networks

(0368-3030) / Fall 2013

The Blavatnik School of Computer Science,
Tel-Aviv University

Allon Wagner

A decorative graphic consisting of several horizontal lines of varying lengths and colors (teal, light blue, white) extending from the right side of the slide towards the center.

Reliable Data Transfer

Kurose & Ross, Chapter 3.4 (5th ed.)

Many slides adapted from:

J. Kurose & K. Ross \

Computer Networking: A Top Down Approach (5th ed.)

Addison-Wesley, April 2009.

Copyright 1996-2010, J.F Kurose and K.W. Ross, All Rights Reserved.

rdt3.0 sender

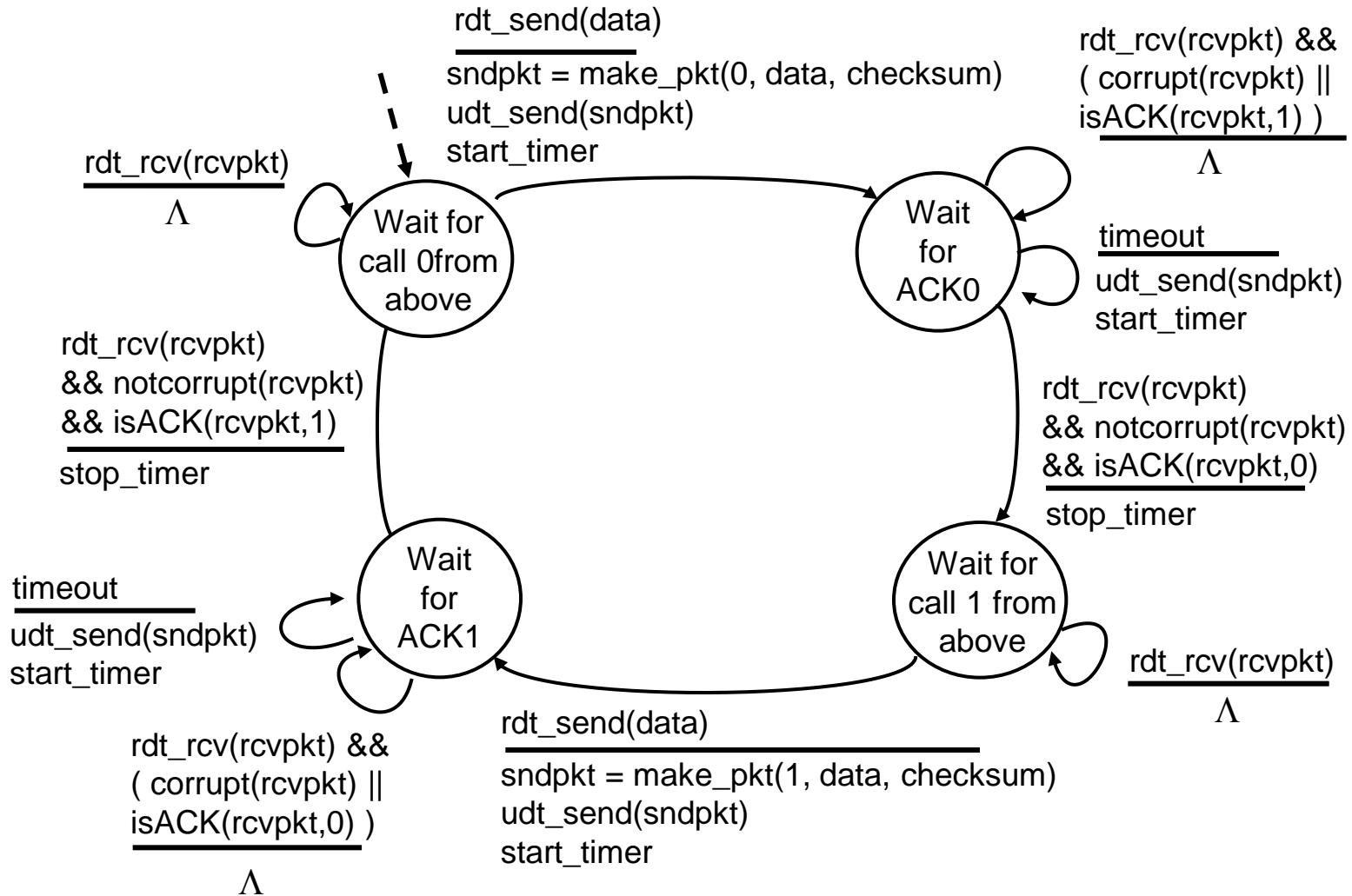

rdt3.0 in action

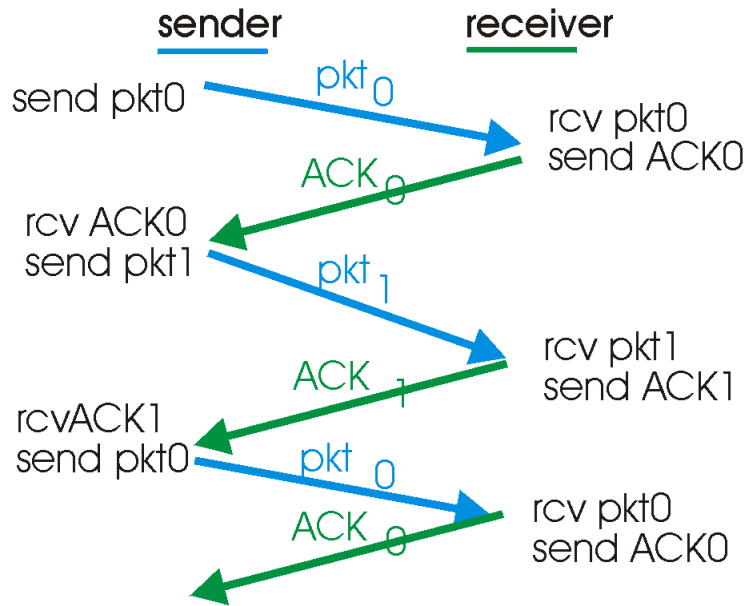

(a) operation with no loss

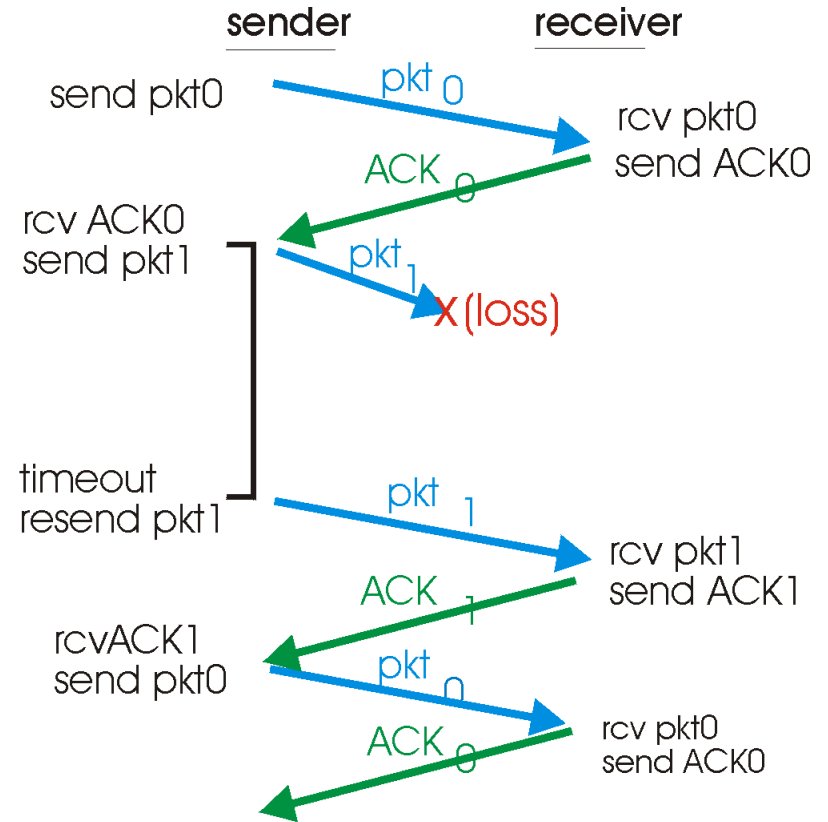

(b) lost packet

rdt3.0 in action

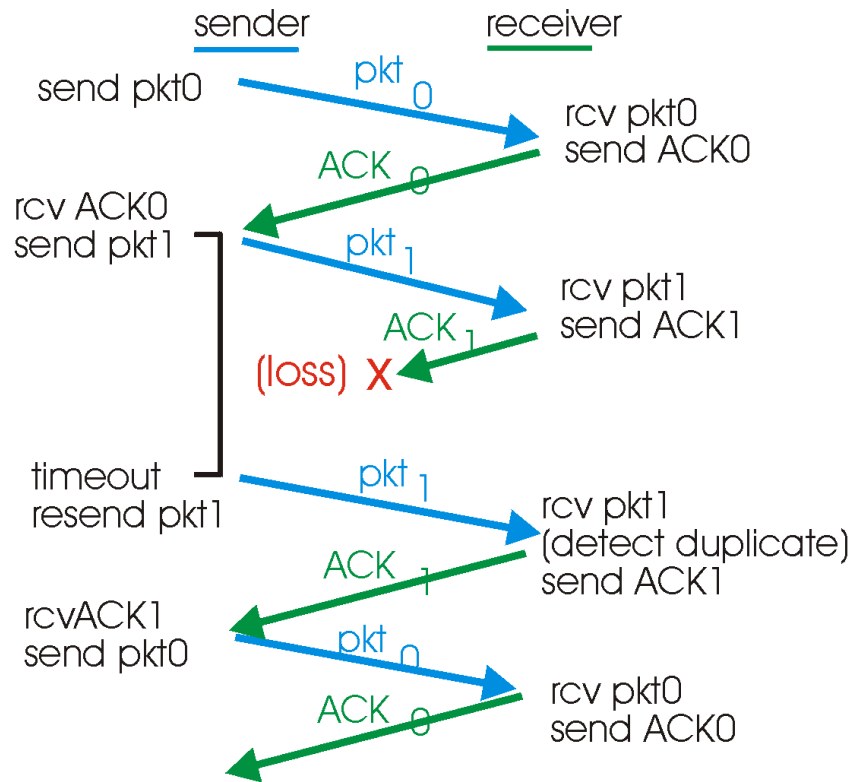

(c) lost ACK

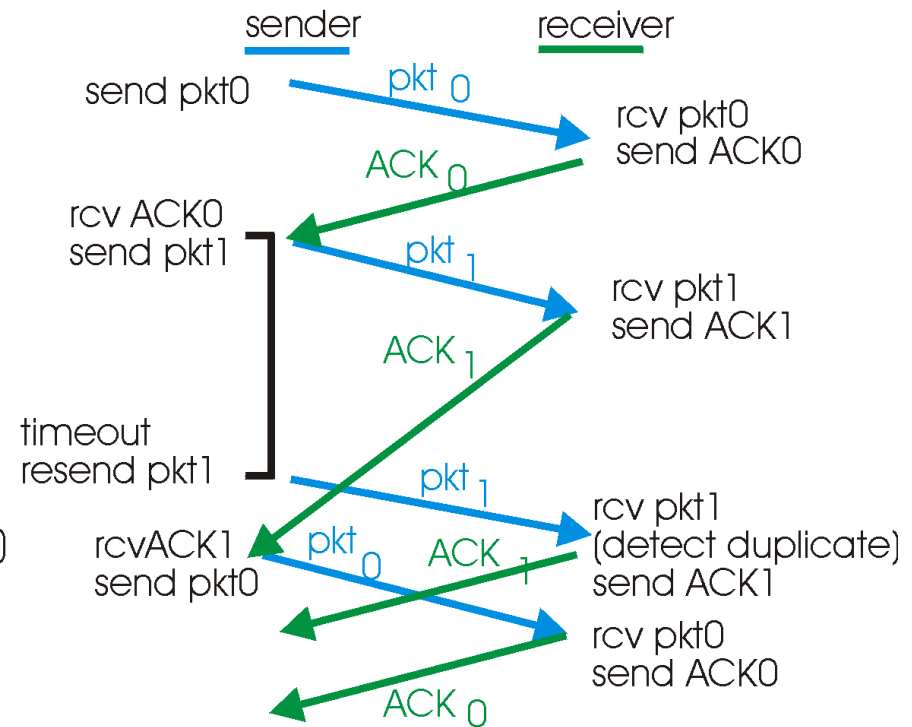

(d) premature timeout

Exercise (Kurose & Ross, 5th ed.)

- rdt 3.0 is correct only under a FIFO channel assumption.
 - Correct = guarantees reliable transmission. Data sent by sender is exactly the data reconstructed in the receiver side.
- Show a case where a non-FIFO channel (i.e., one that can cause packet reordering) causes rdt 3.0 to deliver incorrect data.

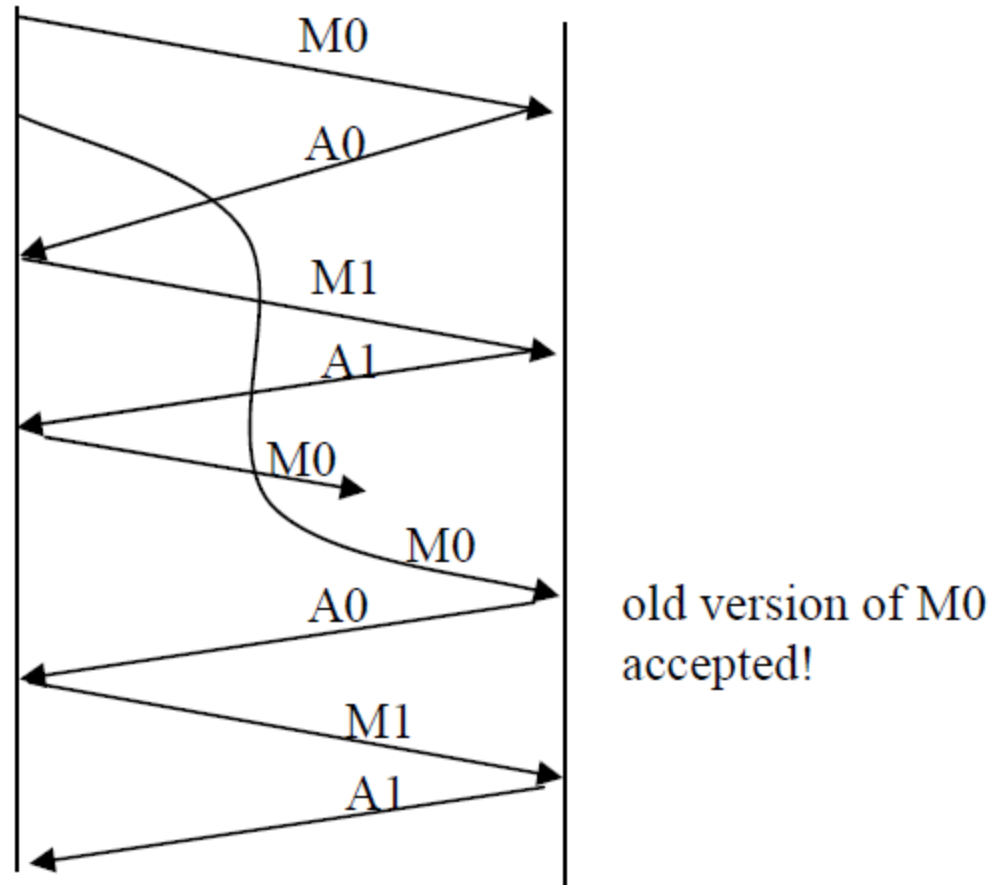

Exercise (Kurose & Ross, 5th ed.)

- The sender of rdt 3.0 simply ignores all received packets that are either in error or have the wrong value in the acknum field of an ack packet.
- Suppose that in such circumstances, rdt 3.0 were simply to transmit the current data packet.
- Would the protocol still work?
- Would it be more or less efficient than before?

Exercise (Kurose & Ross, 5th ed.)

- Would the protocol still work?
 - Yes. A retransmission is exactly what would happen if the sender's timeout expired (for instance, because an ack was completely lost instead of garbled).
 - The receiver can't even distinguish between the two events.

Exercise (Kurose & Ross, 5th ed.)

- Would it be more or less efficient than before?
 - Depends on the length of the sender timeout, compared to the expected channel delay.
 - If the timeout is very long, then the immediate retransmit can save us the long wait until the timeout expires.
 - However, premature timeouts can cause a pathologies.

Exercise (Kurose & Ross, 5th ed.)

- Would it be more or less efficient than before?
- We will show a scenario in which one premature timeout causes duplication of all the packets in the session from a certain time point.
- This is the “Sorcerer’s Apprentice Syndrome”

premature
timeout

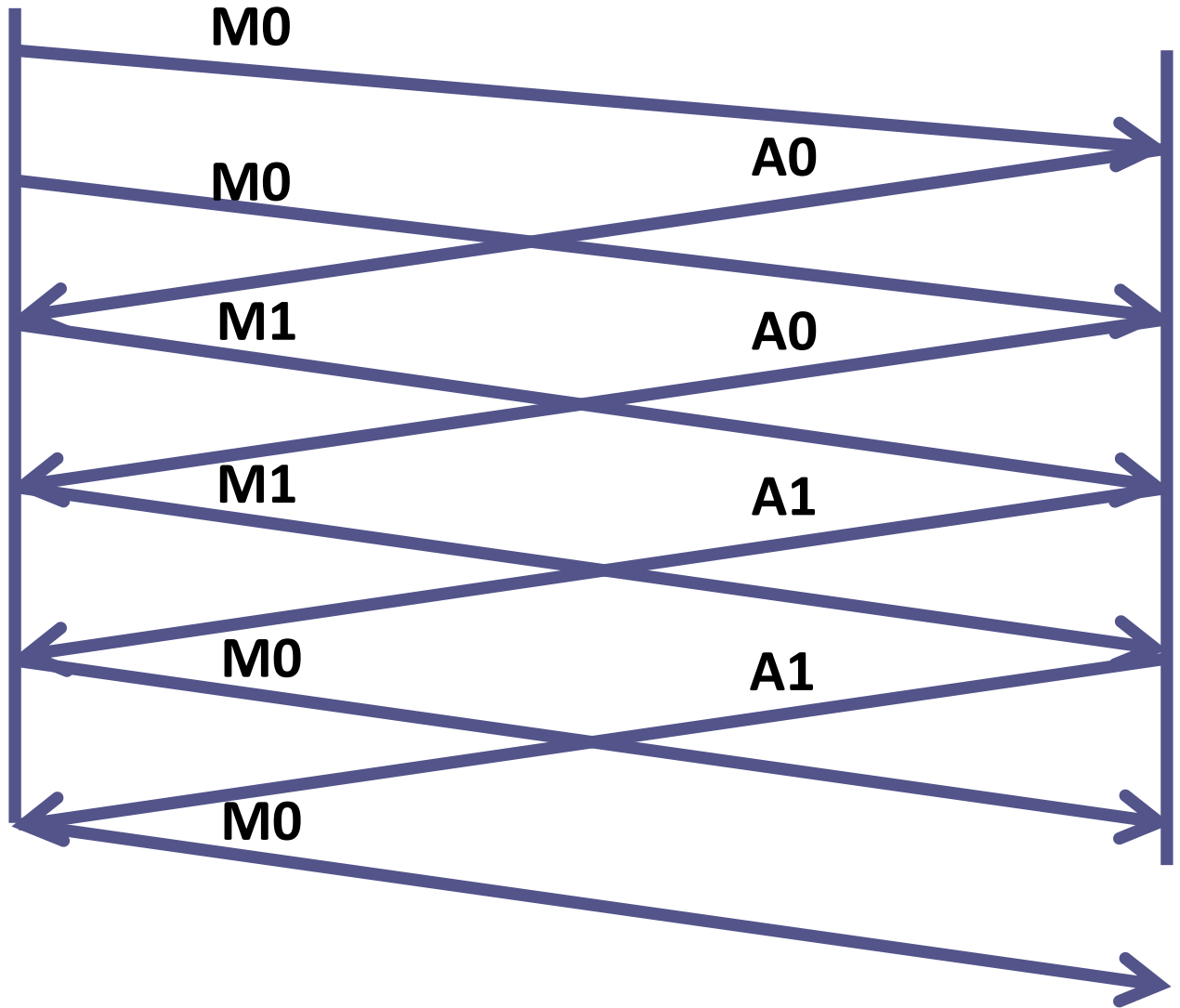

Performance of rdt3.0

- ❖ rdt3.0 works, but performance stinks
- ❖ ex: 1 Gbps link, 15 ms prop. delay, 8000 bit packet:

$$d_{trans} = \frac{L}{R} = \frac{8000\text{bits}}{10^9\text{bps}} = 8\text{microseconds}$$

- U_{sender} : **utilization** - fraction of time sender busy sending

$$U_{\text{sender}} = \frac{L / R}{RTT + L / R} = \frac{.008}{30.008} = 0.00027$$

- if RTT=30 msec, 1KB pkt every 30 msec -> 33kB/sec thruput over 1 Gbps link
- network protocol limits use of physical resources!

rdt3.0: stop-and-wait operation

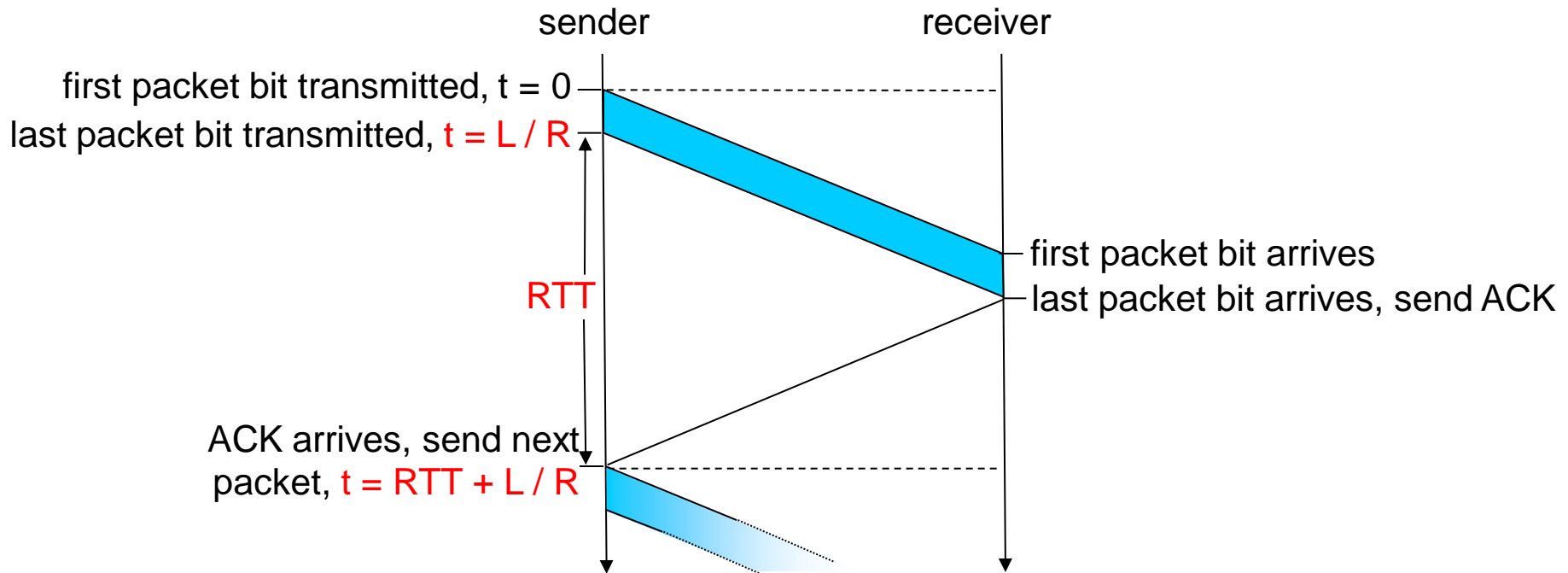

$$U_{\text{sender}} = \frac{L/R}{RTT + L/R} = \frac{.008}{30.008} = 0.00027$$

Pipelined protocols

pipelining: sender allows multiple, "in-flight", yet-to-be-acknowledged pkts

- range of sequence numbers must be increased
- buffering at sender and/or receiver

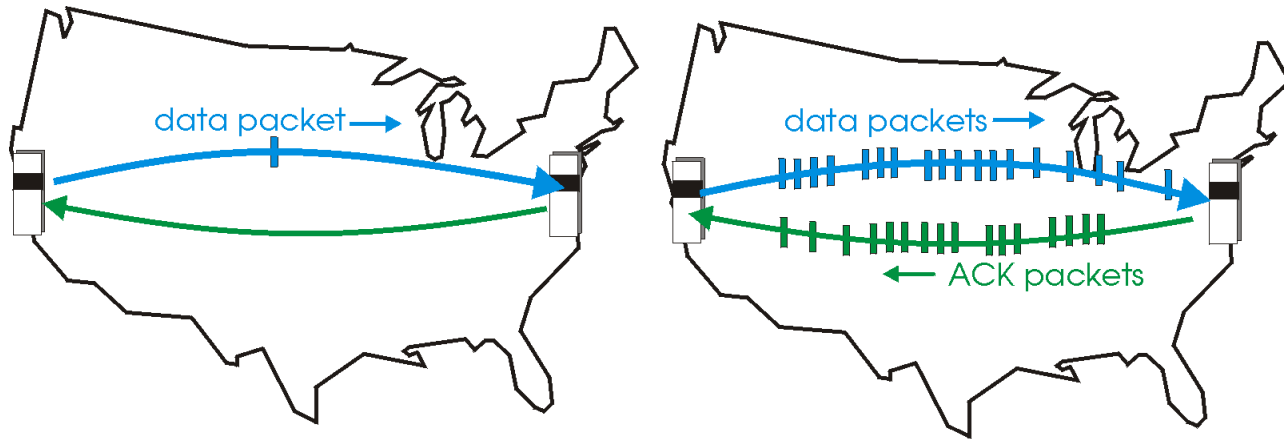

(a) a stop-and-wait protocol in operation

(b) a pipelined protocol in operation

- ❖ two generic forms of pipelined protocols: *go-Back-N*, *selective repeat*

Pipelining: increased utilization

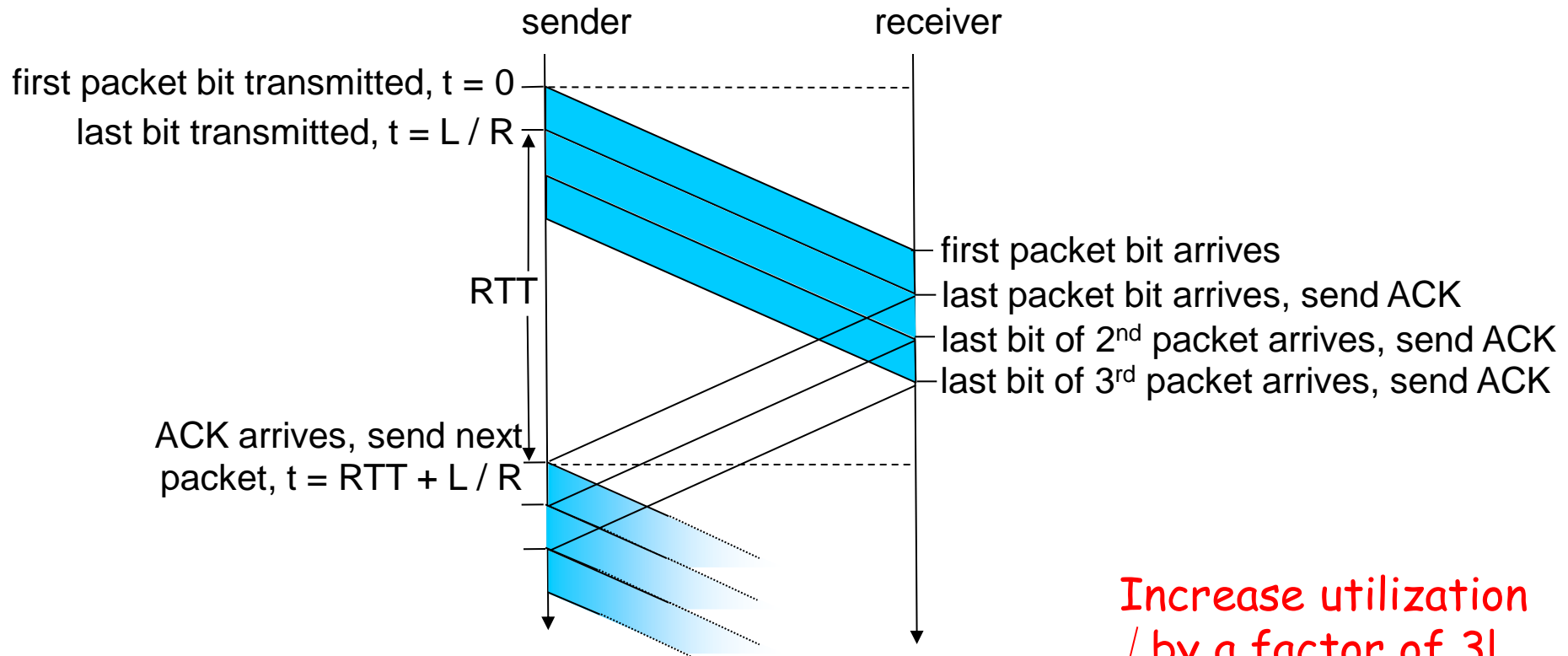

Increase utilization
by a factor of 3!

$$U_{\text{sender}} = \frac{3 * L / R}{RTT + L / R} = \frac{.024}{30.008} = 0.0008$$

Pipelined Protocols

Go-back-N: big picture:

- ❖ sender can have up to N unacked packets in pipeline
- ❖ rcvr only sends *cumulative* acks
 - doesn't ack packet if there's a gap
- ❖ sender has timer for oldest unacked packet
 - if timer expires, retransmit all unack'ed packets

Selective Repeat: big pic

- ❖ sender can have up to N unack'ed packets in pipeline
- ❖ rcvr sends *individual ack* for each packet
- ❖ sender maintains timer for each unacked packet
 - when timer expires, retransmit only unack'ed packet

Go-Back-N

Sender:

- ❖ k-bit seq # in pkt header
- ❖ "window" of up to N, consecutive unack'ed pkts allowed

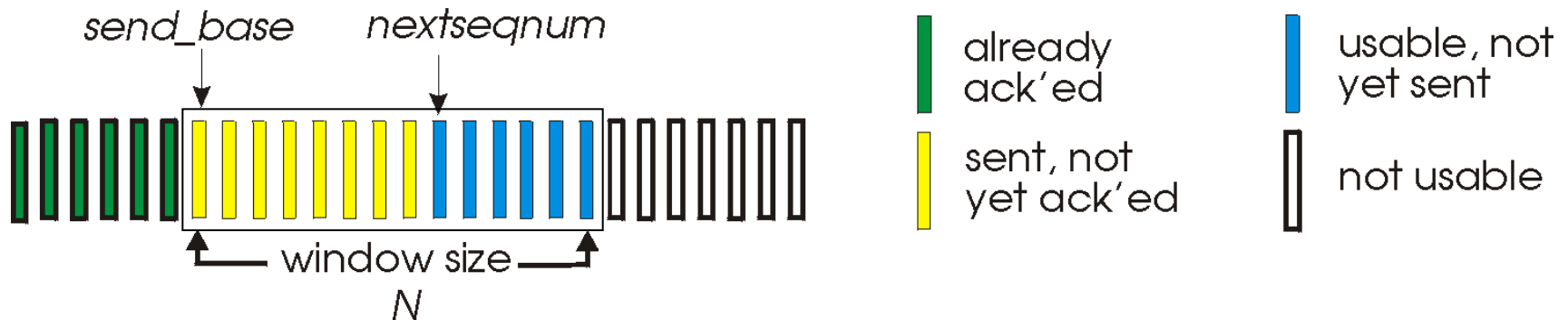

- ❖ $ACK(n)$: ACKs all pkts up to, including seq # n - "cumulative ACK"
 - may receive duplicate ACKs (see receiver)
- ❖ timer for each in-flight pkt
- ❖ $timeout(n)$: retransmit pkt n and all higher seq # pkts in window

GBN: sender extended FSM

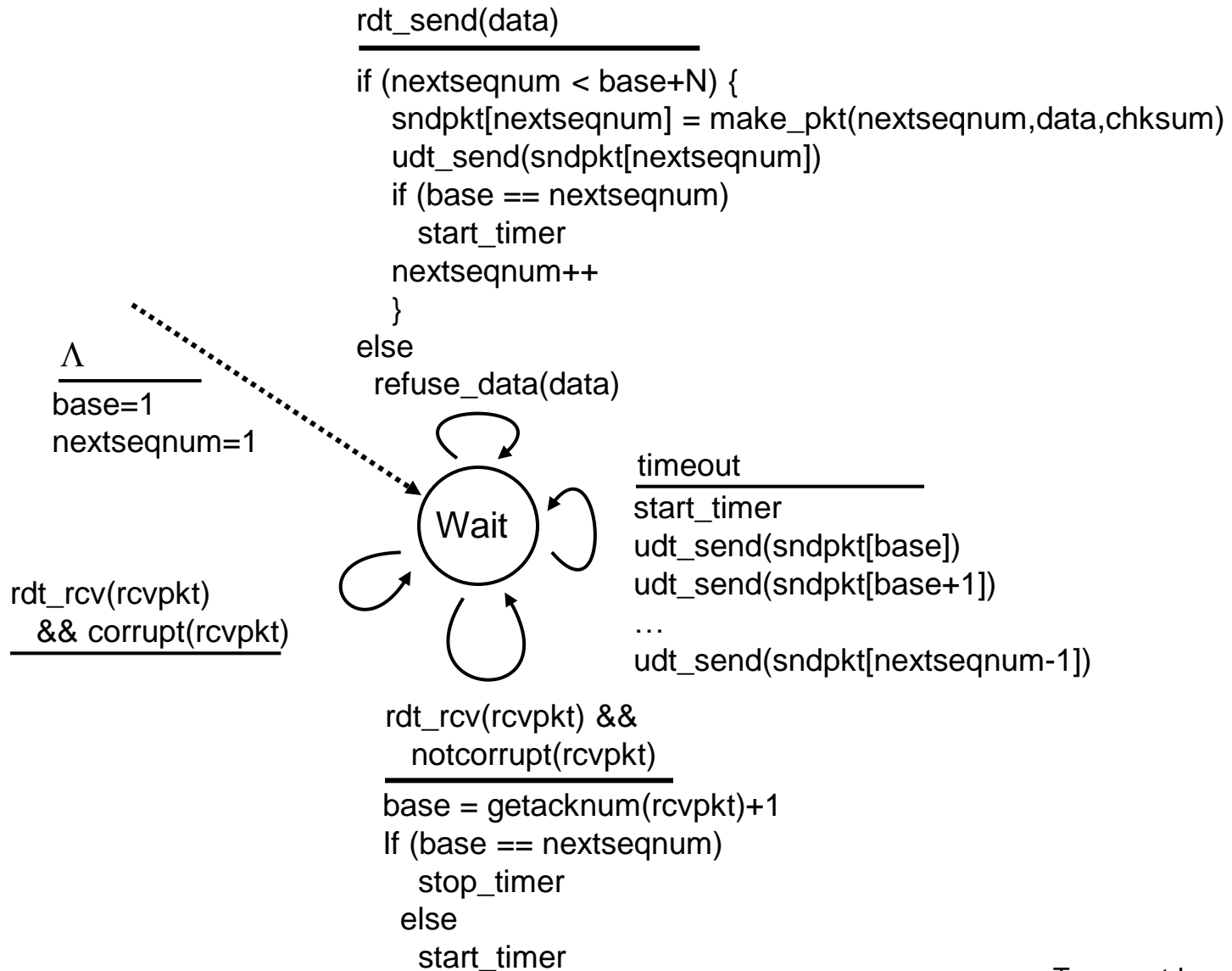

GBN: receiver extended FSM

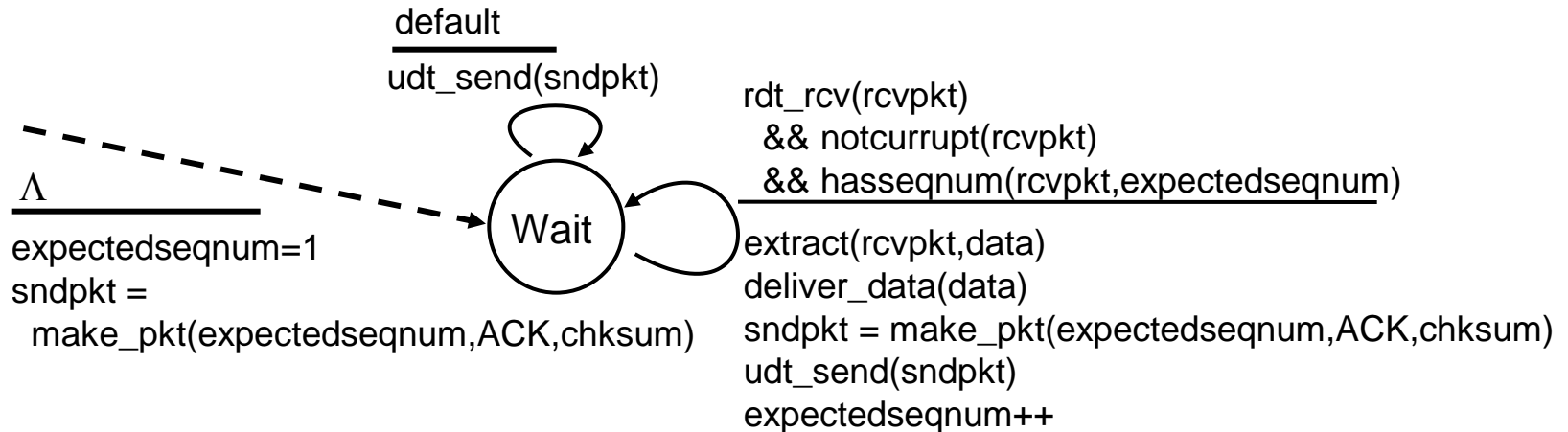

ACK-only: always send ACK for correctly-received pkt with highest *in-order* seq #

- may generate duplicate ACKs
- need only remember **expectedseqnum**

❖ out-of-order pkt:

- discard (don't buffer) -> **no receiver buffering!**
- Re-ACK pkt with highest in-order seq #

GBN in action

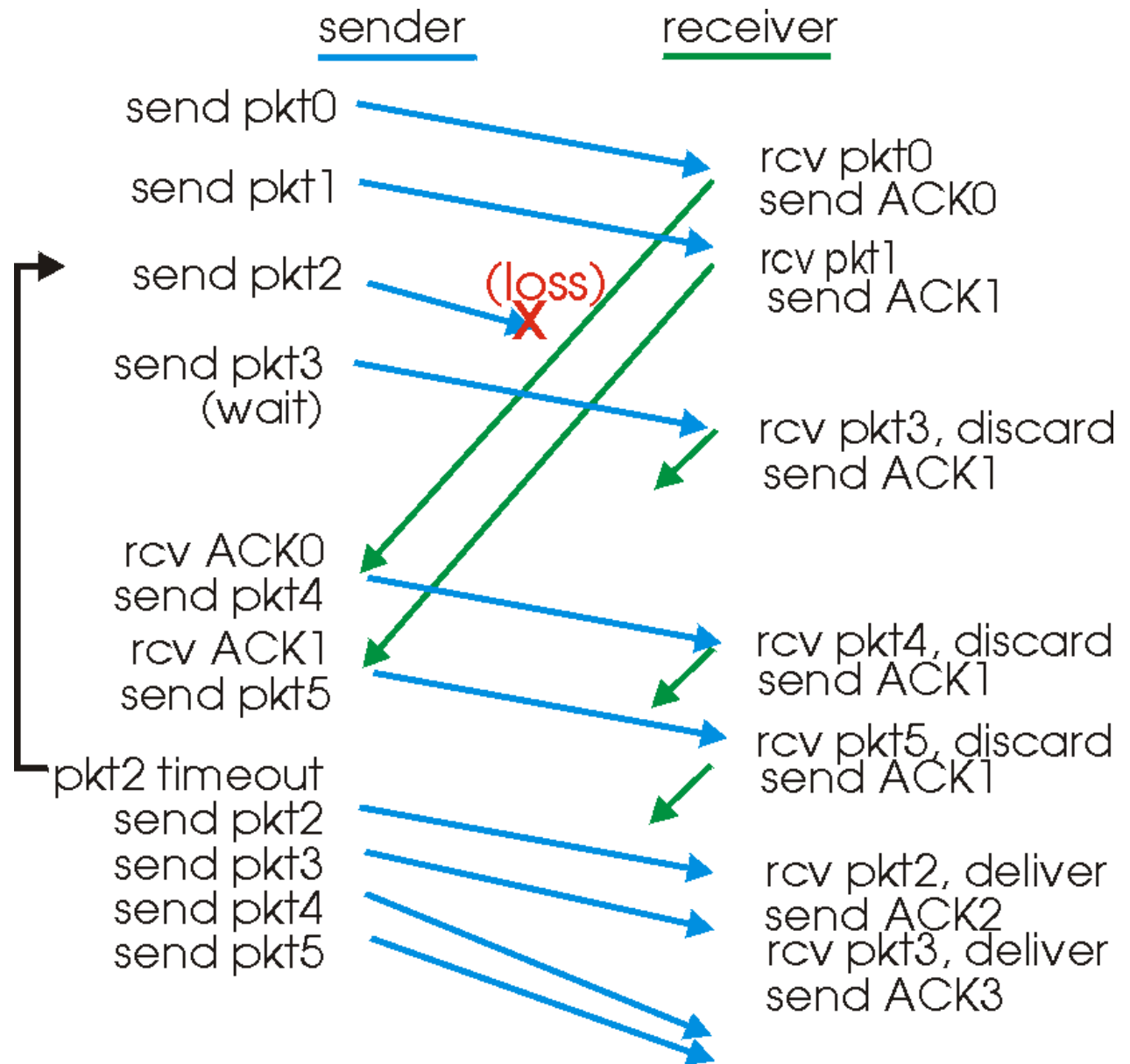

Selective Repeat

- ❖ receiver *individually* acknowledges all correctly received pkts
 - buffers pkts, as needed, for eventual in-order delivery to upper layer
- ❖ sender only resends pkts for which ACK not received
 - sender timer for each unACKed pkt
- ❖ sender window
 - N consecutive seq #'s
 - again limits seq #'s of sent, unACK'ed pkts

Selective repeat: sender, receiver windows

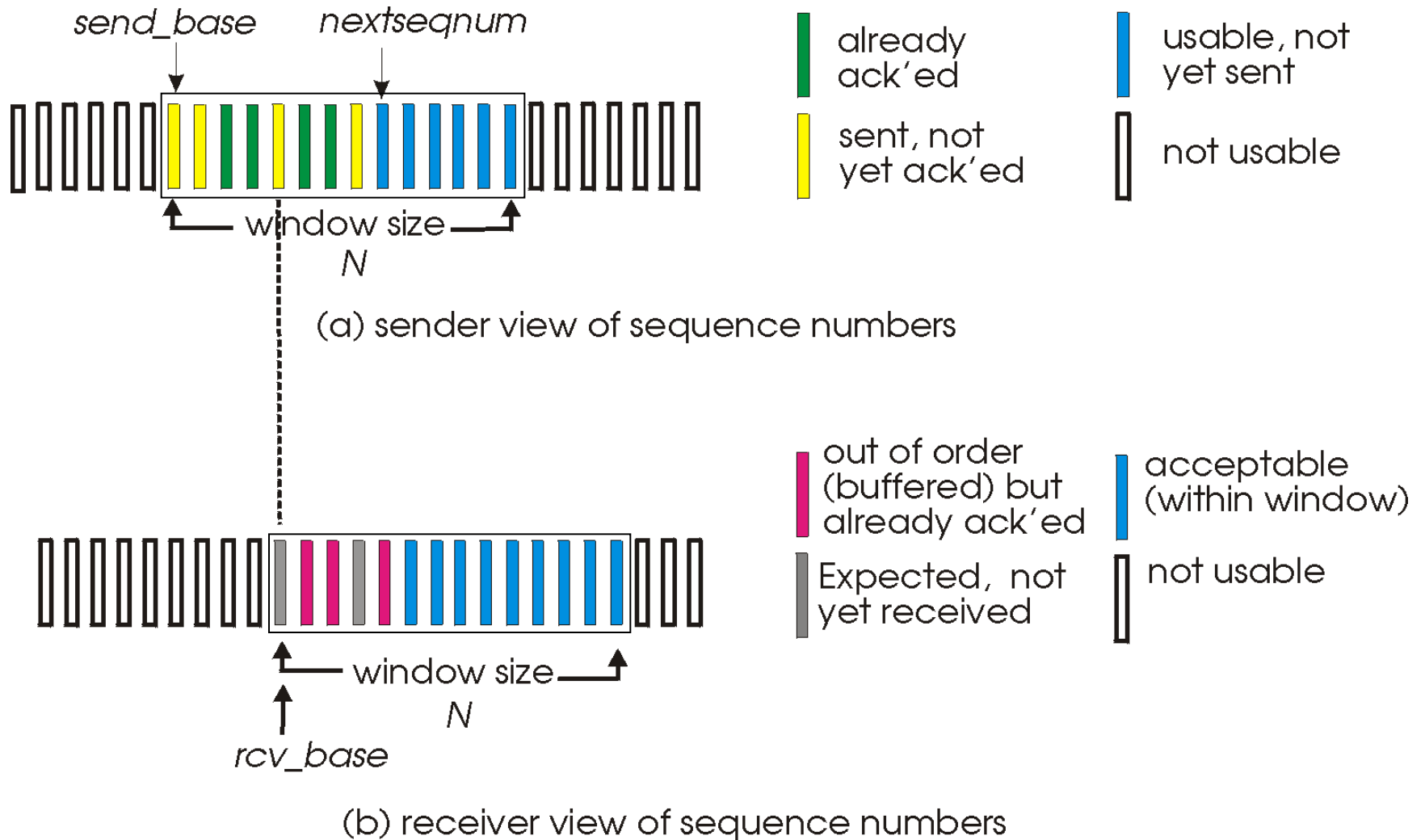

Selective repeat

sender

data from above :

- ❖ if next available seq # in window, send pkt

timeout(n):

- ❖ resend pkt n, restart timer

ACK(n) in [sendbase,sendbase+N]:

- ❖ mark pkt n as received
- ❖ if n smallest unACKed pkt, advance window base to next unACKed seq #

receiver

pkt n in [rcvbase,rcvbase+N-1]

- ❖ send ACK(n)
- ❖ out-of-order: buffer
- ❖ in-order: deliver (also deliver buffered, in-order pkts), advance window to next not-yet-received pkt

pkt n in [rcvbase-N,rcvbase-1]

- ❖ ACK(n)

otherwise:

- ❖ ignore

Selective repeat in action

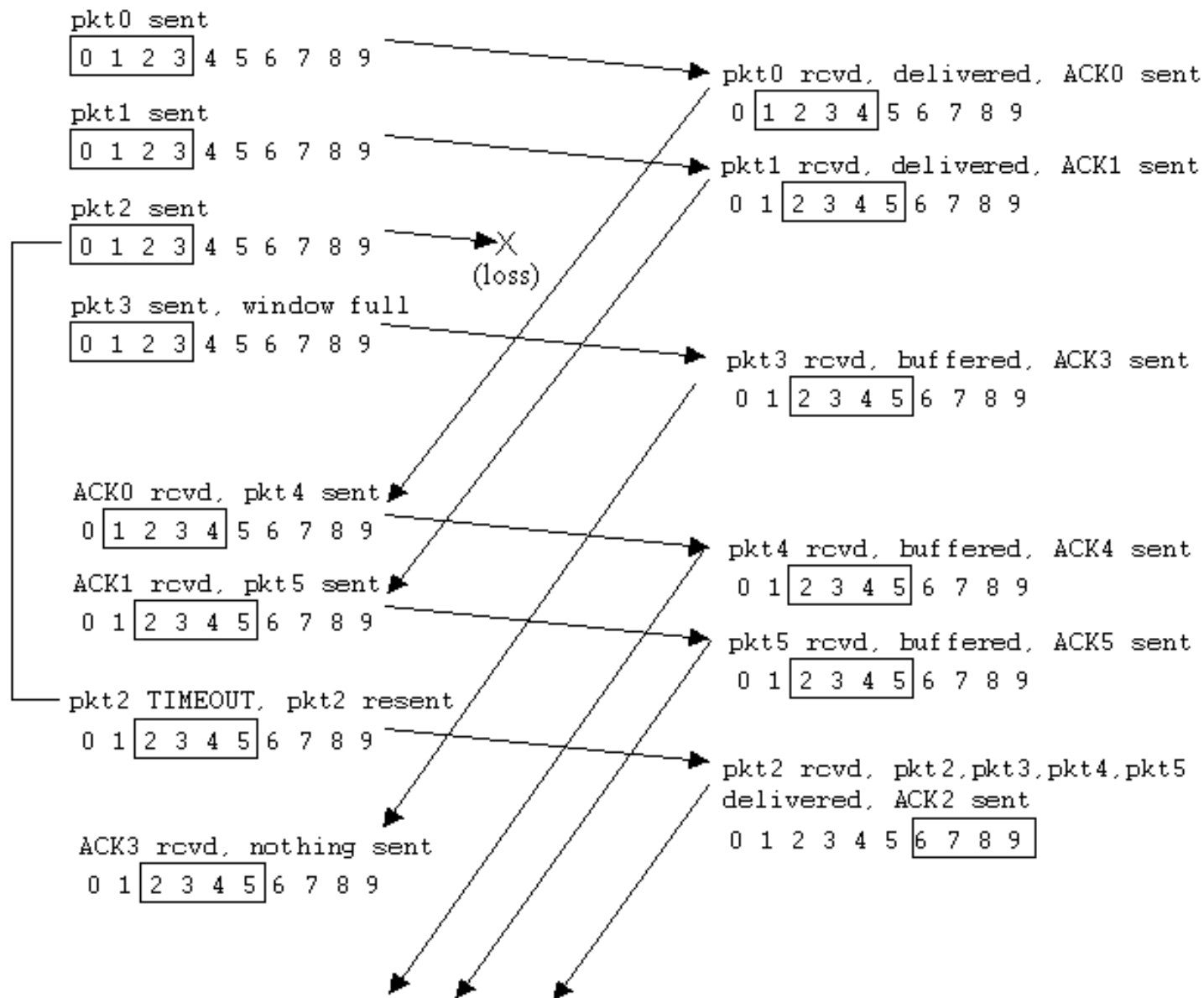

Selective repeat: dilemma

Example:

- ❖ seq #'s: 0, 1, 2, 3
- ❖ window size=3

- ❖ receiver sees no difference in two scenarios!
- ❖ incorrectly passes duplicate data as new in (a)

- Q: what relationship between seq # size and window size?

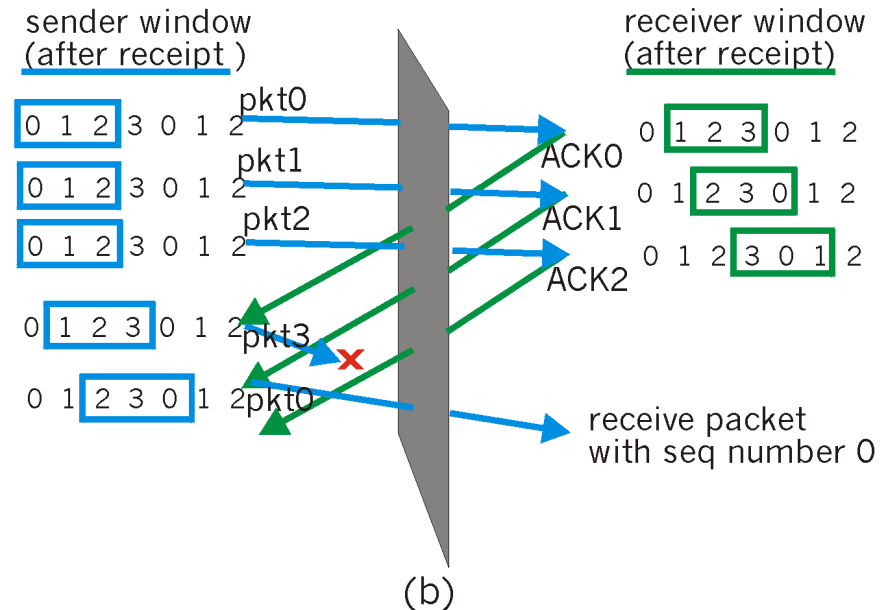
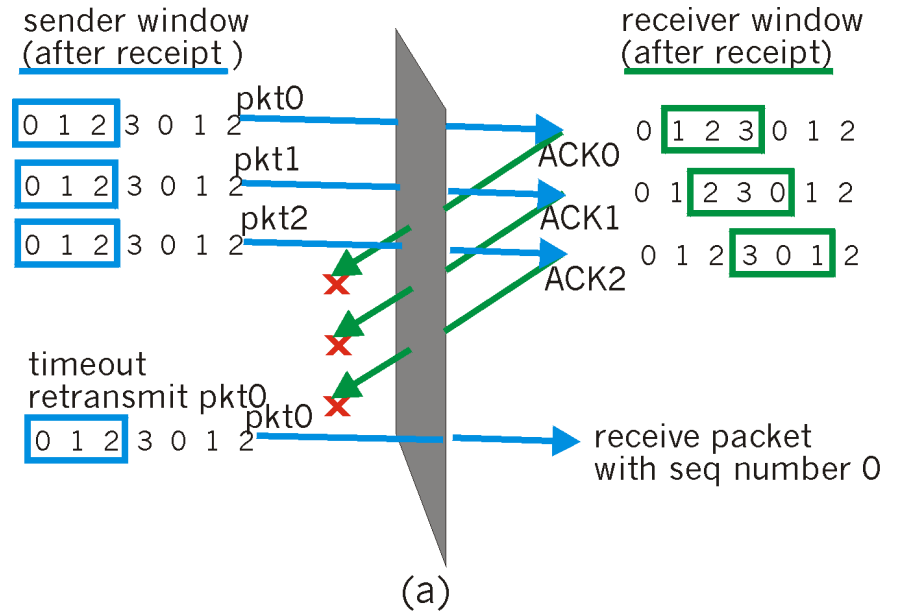

Minimal sequence range

- Assume we want to use a **sender window of size N** .
- What is the **minimal number of unique sequence numbers** we should allow to prevent such errors?
- The cyclic sequence number should never cause the sender and receiver's window to ambiguously overlap
- In FIFO channels:
 - **GBN: $N + 1$**
 - **SR: $2N$**
 - **Proof: on-board**

Minimal sequence range (cont.)

- In non-FIFO channel, this cannot be guaranteed!
 - We assume that in realistic channels, old packets are cleared from the network after a reasonable time, so accidental overlap does not occur of the range of sequence numbers is “big enough”.

Exercise (Kurose & Ross, 5th ed.)

- Are the following statements true or false?
- With SR, it is possible for the sender to receive an ACK for a packet that falls outside of its current window.
- True. Suppose sender has a window size of 3.
 - Time t_0 : it sends packets 1, 2, 3.
 - Time $t_1 > t_0$: receiver acks 1, 2, 3.
 - Time $t_2 > t_1$: sender times out and retransmits 1, 2, 3.
 - Time $t_3 > t_2$: receiver gets the duplicates and reacks 1, 2, 3.
 - Time $t_4 > t_3$: sender gets the ack sent at t_1 , advances its window to 4, 5, 6.
 - Time $t_5 > t_4$: sender receives the acks sent at t_2 , that fall outside of its current window.
- With GBN, it is possible for the sender to receive an ACK for a packet that falls outside of its current window.
- True, with the same scenario as described above. Only need to replace the selective acks with cumulative acks.

Exercise (Kurose & Ross, 5th ed.)

- Are the following statements true or false?
- rdt 3.0 is the same as SR with a sender and receiver window size of 1.
- rdt 3.0 is the same as GBN with a sender and receiver window size of 1.
- Both are true. With a window size of 1, SR, GBN, and the rdt 3.0 are functionally equivalent.
 - The window size of 1 precludes the possibility of out-of-order packets (within the window).
 - A cumulative ACK is just an ordinary ACK in this situation, since it can only refer to the single packet within the window.

Exercise

- Recall the GBN receiver: assume it is waiting for packet m (i.e., it received correctly all the packets up to $m - 1$ inclusive).
 - When a data packet with sequence $n = m$ is received, the receiver accepts it and advances its window.
 - Whenever a data packet with sequence $n \neq m$ is received, the receiver discards it and resends ack m (“I am still waiting for m ”).
- Assume a FIFO channel and an infinite sequence number. Does the protocol remain correct if we perform the following changes?
- If $n < m$ the receiver discards the packet and does not send an ack. Otherwise, operate as before.
- **Incorrect.** Let the sender send packets $1, \dots, m - 1$. All received correctly, but all acks are lost.
 - The receiver waits for packet m .
 - But whenever the sender times-out expires, it resends packets $1, \dots, m - 1$.
 - Receiver discards them and does not ack.
 - Deadlock.

Exercise

- if $n > m$, the receiver discards the packet and does not send an ack. Otherwise, operate as before.
- Correct. If $n > m$ was received, but the receiver is waiting for m , it means we have a gap. The sender will eventually timeout for m , and resend packet n then.