

# Communication Networks (0368-3030) / Spring 2011

The Blavatnik School of Computer Science,  
Tel-Aviv University

Allon Wagner



## Hubs, Bridges, Switches

Kurose & Ross, Chapters 5.5 - 5.6 (5<sup>th</sup> ed.)

Tanenbaum & Wetherall, Chapters 4.3.4 – 4.3.8 (5<sup>th</sup> ed.)

Many slides adapted from:

J. Kurose & K. Ross \

Computer Networking: A Top Down Approach (5<sup>th</sup> ed.)

Addison-Wesley, April 2009.

Copyright 1996-2010, J.F Kurose and K.W. Ross, All Rights Reserved.

### Hubs

... physical-layer ("dumb") repeaters:

- bits coming in one link go out *all* other links at same rate
- all nodes connected to hub can collide with one another
- no frame buffering
- no CSMA/CD at hub: host NICs detect collisions

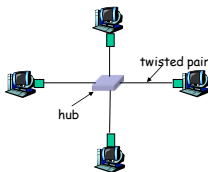

Data Link Layer 5-3

### Switch

❖ *link-layer device: smarter than hubs, take active role*

- store, forward Ethernet frames
- examine incoming frame's MAC address, *selectively* forward frame to one-or-more outgoing links when frame is to be forwarded on segment, uses CSMA/CD to access segment

❖ *transparent*

- hosts are unaware of presence of switches

❖ *plug-and-play, self-learning*

- switches do not need to be configured

Data Link Layer 5-4

### Switch: allows multiple simultaneous transmissions

- hosts have dedicated, direct connection to switch
- switches buffer packets
- Ethernet protocol used on *each* incoming link, but no collisions; full duplex
  - each link is its own collision domain
- switching*: A-to-A' and B-to-B' simultaneously, without collisions
  - not possible with dumb hub

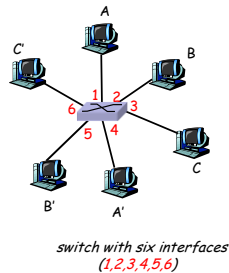

Data Link Layer 5-5

### Switch Table

❖ *Q*: how does switch know that A' reachable via interface 4, B' reachable via interface 5?

❖ *A*: each switch has a **switch table**, each entry:

- (MAC address of host, interface to reach host, time stamp)

❖ looks like a routing table!

❖ *Q*: how are entries created, maintained in switch table?

- something like a routing protocol?

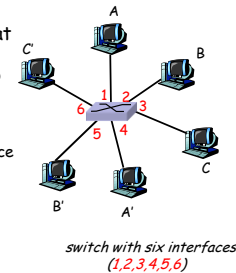

Data Link Layer 5-6

### Switch: self-learning

- switch *learns* which hosts can be reached through which interfaces
  - when frame received, switch "learns" location of sender: incoming LAN segment
  - records sender/location pair in switch table

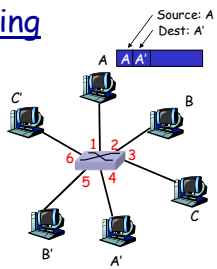

MAC addr	interface	TTL
A	1	60

Switch table (initially empty)

Data Link Layer 5-7

### Switch: frame filtering/forwarding

When frame received:

- record link associated with sending host
- index switch table using MAC dest address
- if entry found for destination
  - then {
    - if dest on segment from which frame arrived then drop the frame
    - else forward the frame on interface indicated
  - } else flood

*forward on all but the interface on which the frame arrived*

Data Link Layer 5-8

### Self-learning, forwarding: example

- frame destination unknown: *flood*
- destination A location known: *selective send*

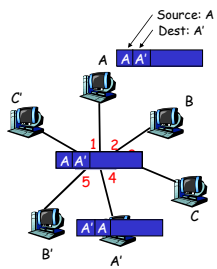

MAC addr	interface	TTL
A	1	60
A'	4	60

Switch table (initially empty)

Data Link Layer 5-9

### Interconnecting switches

- switches can be connected together

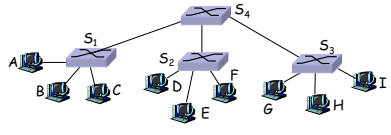

- Q:** sending from A to G - how does S1 know to forward frame destined to F via S4 and S3?
- A:** self learning! (works exactly the same as in single-switch case!)

Data Link Layer 5-10

### Self-learning multi-switch example

Suppose C sends frame to I, I responds to C

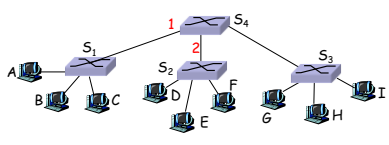

- Q:** show switch tables and packet forwarding in S1, S2, S3, S4

Data Link Layer 5-11

### Institutional network

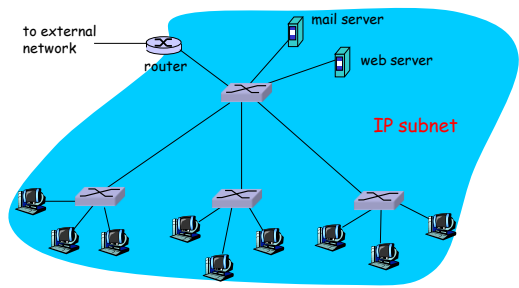

Data Link Layer 5-12

Question

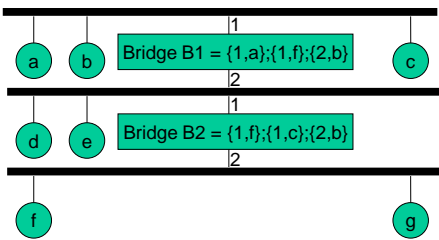

Find all errors in the table and explain why?

Bridge name	Error in table	Explain

All Errors

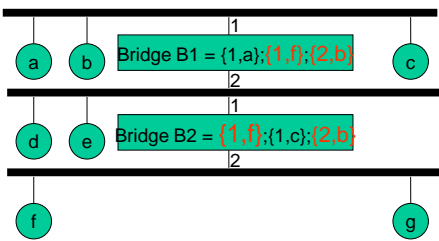

Does a message reaches destination?

- From C to G
- From A to F
- From F to A

What will happen to the tables?

From C to G

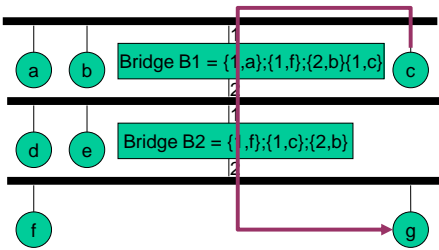

From A to F

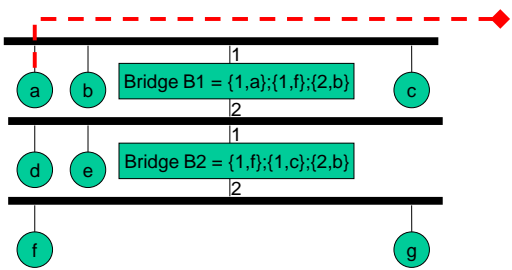

From F to A

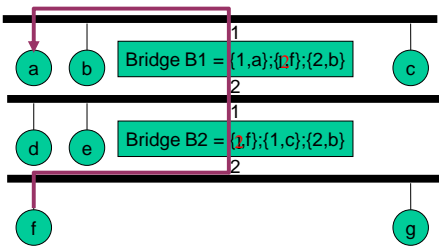

What will happen with loops?  
Incorrect learning

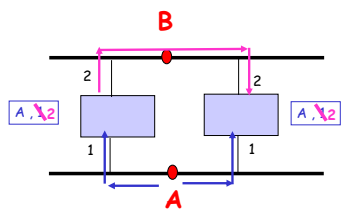

Lecture 3 #20

What will happen with loops?  
Frame looping

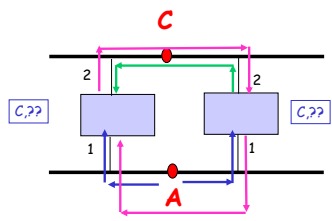

Lecture 3 #21

What will happen with loops?  
Frame looping

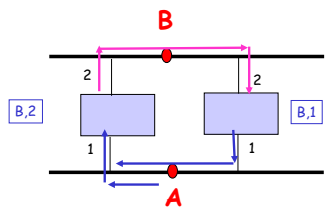

Lecture 3 #22

Loop-free: tree

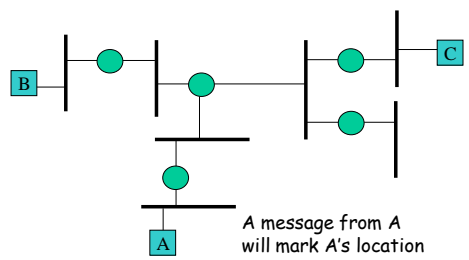

Lecture 3 #23

Loop-free: tree

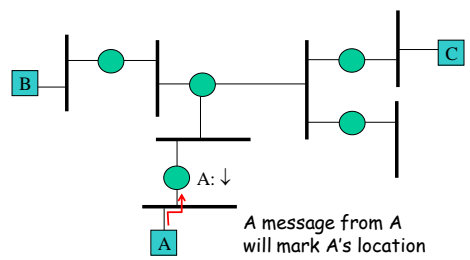

Lecture 3 #24

Loop-free: tree

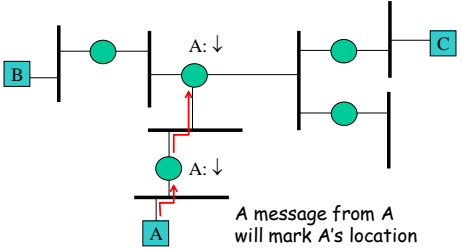

Lecture 3 #25

Loop-free: tree

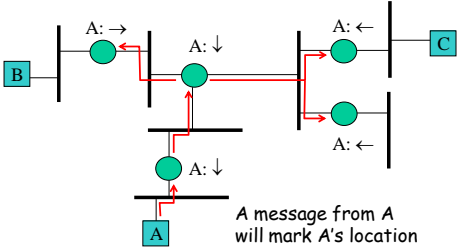

Lecture 3 #26

Loop-free: tree

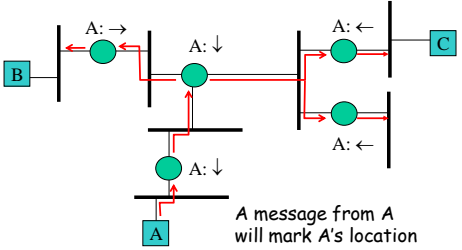

Lecture 3 #27

Loop-free: tree

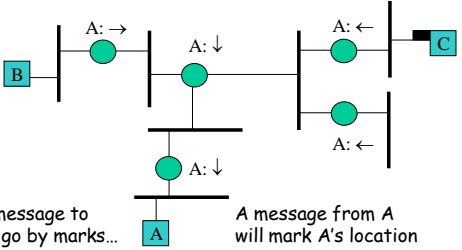

Lecture 3 #28

**The Spanning Tree Protocol (STP)**

Perlman, Chapters 3.3 - 3.5 (2<sup>th</sup> ed.)  
Peterson & Davie, Chapter 3.2.2 (3<sup>th</sup> ed.)

Introduction

- Developed by Radia Perlman
- Standardized in IEEE 802.1
  - We will learn the main concepts, and skip some of the technical drudgery
  - Refer to Perlman's book or to the standard for a complete description
- Bridges run a **distributed** spanning tree algorithm
  - Select which ports (and bridges) should actively forward frames
  - Dynamic, adapts itself to topology changes

## STP's goal

- Create a spanning-tree of the LAN segments in the extended LAN
- This is done by logically removing ports from the network in order to reduce it to an acyclic graph
  - Data traffic is discarded upon receipt in ports not selected for inclusion in the spanning tree.
  - Sometimes, an entire bridge will be removed from the network

## STP preliminaries

- Bridges regularly exchange frames known as Configuration Bridge Protocol Data Units (Configuration BPDUs).
- Every bridge has a unique ID. The bridge with the smallest ID is the root bridge.
- Each config message transmitted by bridge B contains:
  - Root ID: ID of the bridge R which B currently considers to be the root
  - Cost: Least cost path from B to R (of all the paths B is currently aware of)
  - Transmitting Bridge ID: B's ID.

## STP preliminaries (cont.)

- A bridge initially assumes itself to be the root and transmits frames on all ports indicating it to be the root with cost 0.
- Each bridge B saves for each port the best frame it had seen so far on this port. "Best" means:
  - Smaller root ID
  - If root IDs are equal: lower cost to the root
    - Cost is the sum of the cost indicates in the message B had received, and the cost of the link on which it was received
    - Often cost is measured in hops, and thus is simply cost in msg + 1.
  - If root IDs and costs are equal: transmitting bridge has lower ID
  - If still a tie: break ties by port identifier
    - For simplicity's sake, we'll ignore that in our presentation

## Example 1 (adapted from Perlman)

C1			C2		
Root ID	Cost	Transmitter	Root ID	Cost	Transmitter
29	15	35	31	12	32
35	15	80	35	18	38
35	80	39	35	80	40

- In all three case, config message C1 is better than C2 (assuming cost is hops)
  1. Smaller root ID
  2. Smaller distance to the same root
  3. Same root and distance, but through a bridge with smaller ID.

## Example 2 (adapted from Perlman)

- Bridge 92 has 5 ports
- It saves the best config message it has seen on each port (root ID . Cost to root . Transmitter ID)
- Assume all link costs are 1.

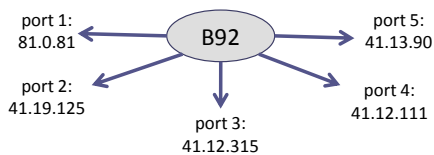

## Example 2 (cont.)

- Bridge 92 assumes the root is 41 and best distance to it is  $12 + 1 = 13$ .
- B41 can be reached in cost 13 either via B315 or via B111. B111 is chosen (smaller ID than B315).
- B92 can transmit the message 41.13.92

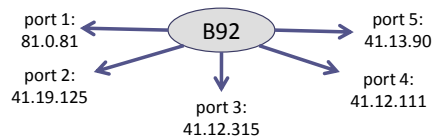

## Selection of Root Port

- Every bridge B accepts one bridge as the root
  - the smallest root ID indicating on any of the ports, or B itself if its ID is even smaller
- B can now select its Root Port
  - the port which indicated the least cost to R
  - will be used to transfer messages towards the root

## Selection of Designated Ports

- For every LAN segment B is connected to B decides whether it is the designated bridge for that LAN:
  - if its config message is the best it had seen on this LAN
  - In that case, the corresponding port becomes the designated port for that LAN.
  - B will be responsible to delivering data frames from the root towards this LAN via the designated port
- A designated port is never also a root port (Why?)
- All the ports of the root bridge are designated (Why?)

## Selecting spanning tree ports

- B forwards data messages only on its root port and its designated ports. Other ports discard data messages upon receipt.
  - It might even be that entire bridges are removed from the network

## Example 2 (cont.)

- Recall that B92 assumes B41 is the root, with cost 13 through B111. Its config message is 41.13.92.
- Port 4 is the root port
- B92 decides it is the designated bridge on the LAN segments connected to ports 1, 2. These are designated ports.

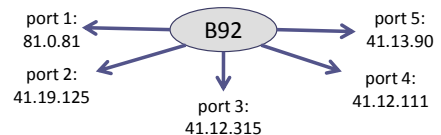

## Example 2 (cont.)

- Ports 1, 2, 4 set to **forwarding state**
- Ports 3, 5 set to **blocking state**

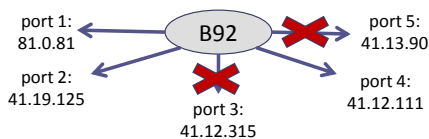

## Example 2 (cont.)

- If the bridge's ID had been 15, it would have decided it was the root port, transmitting the message 15.0.15
- All its ports would have become designated

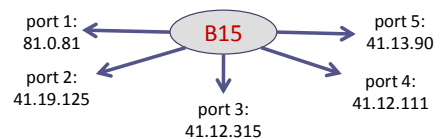

**Example:**

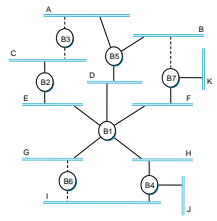

- B1 is the root bridge
- B3 and B5 are both connected to LAN A, but B5 is the designated port since it's closer to root
- B5 and B7 are both connected to LAN B, but B5 is the designated port due to smaller ID (equal distance).

**Designated port / Root Port**

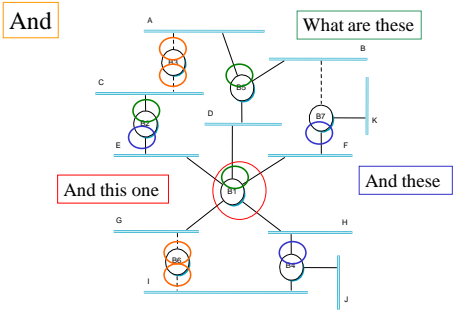

**STP Stabilization**

- Recall that a bridge initially assumes itself to be the root and transmits frames on all ports indicating it to be the root with cost 0.
- When a bridge B accepts another bridge R as the root, it stops generating config messages on its own.
  - B transmits config messages on all its designated ports when triggered to (by)
    - Can you see why only on the designated ports?
  - It adds the relevant link cost (often simply +1) to the cost indicated in them
- When the algorithm stabilizes, only the real root R' generates config messages, and the other bridges forward them on their designated ports

**STP Run - Find Root**

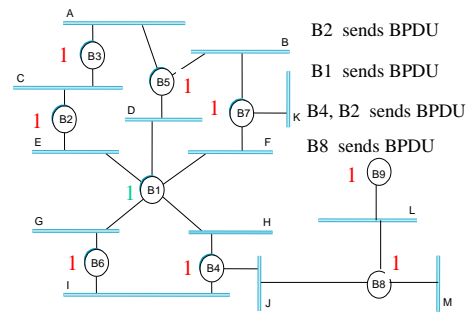

**STP Run - Block Ports**

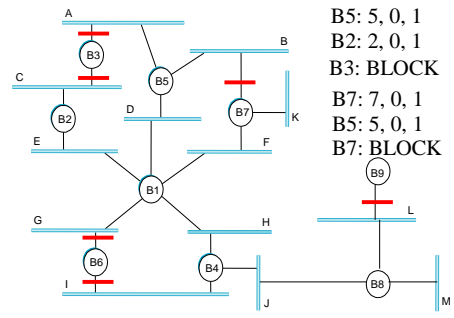

**Data**

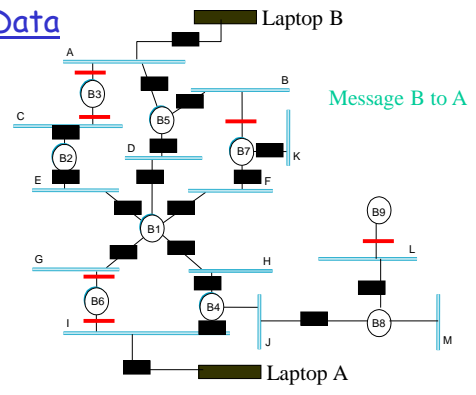



## Topology changes

- STP dynamically adapts to link / bridge additions:
- A new bridge / a bridge with a new port will think it is the root / the designated bridge for the LAN until receiving the appropriate config messages
  - Actually, there are some technicalities here we will not go into

## Topology changes (cont.)

- STP dynamically adapts to link / bridge removal
- Recall that every bridge B saves for each port the best message it had seen on this port
- The entry also holds an "age" field (which is reset by "fresh" config messages).
  - but not always to 0 – again, technicalities
- When a link / bridge fails or is removed from the network "fresh" config messages might stop arriving on some of B's ports:
  - age is increased gradually until the entry expires
  - the STP algorithm kicks in again: B reselects its assumed root, cost to root.